

High Resolution Macro Zoom Lens

High resolution and compact design

- Compatible with 1/1.8" of mega pixel camera
- High resolution and compact design
- High contrast and low distortion
- Improve uniformity of brightness for co-axial illumination
- Magnification and working distance can be converted to 0.21x - 18x, WD40 - 332mm by using converters



HMZ0745 (Manual Zoom/Straight type)

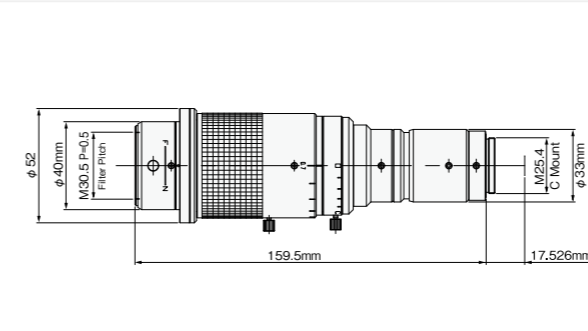

HMZ0745C (Manual Zoom/Co-axial type)

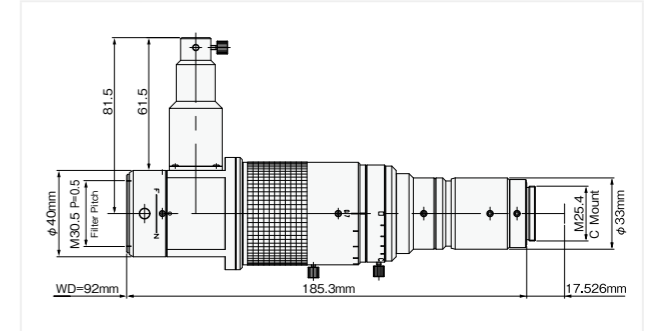

HMZ0745C-SM (Motorized Zoom/Co-axial type)

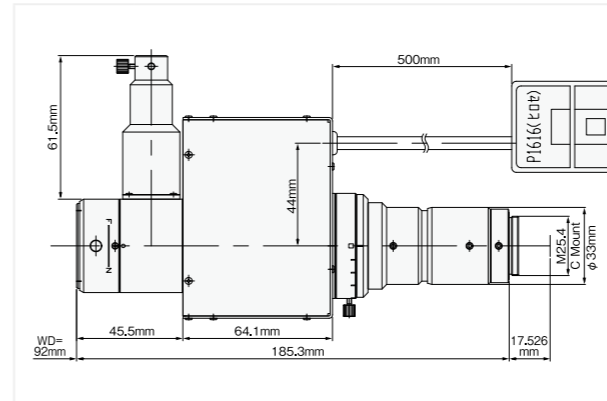

Lens			
Model	HMZ0745 / HMZ0745C / HMZ0745C-SM		
Magnification	0.7x - 4.5x	Depth of field	2mm - 0.08mm
WD	92mm	TV distortion	0.05% - 0.08%
Resolution	11.5 μ - 2.87 μ	Maximum Compatible sensor	1/1.8
Object side NA	0.03 - 0.12		

* Indicated specifications are design values.
 * Resolution indicates a theoretical resolution at a wavelength of 550nm.
 * Depth of field is calculating assuming a horizontal 320 TV resolution using 1/2" camera (permissible circle of confusion 40μ).

Front Converter		
Model	Magnification	WD with converter
HMZ-FC03	0.3x	332mm
HMZ-FC04	0.4x	238mm
HMZ-FC05	0.5x	185mm
HMZ-FC067	0.67x	121mm
HMZ-FC20	2.0x	40mm

Rear Converter	
Model	Magnification
HMZ-RC20	2.0x

(Wiring Diagram) HMZ0745C-SM

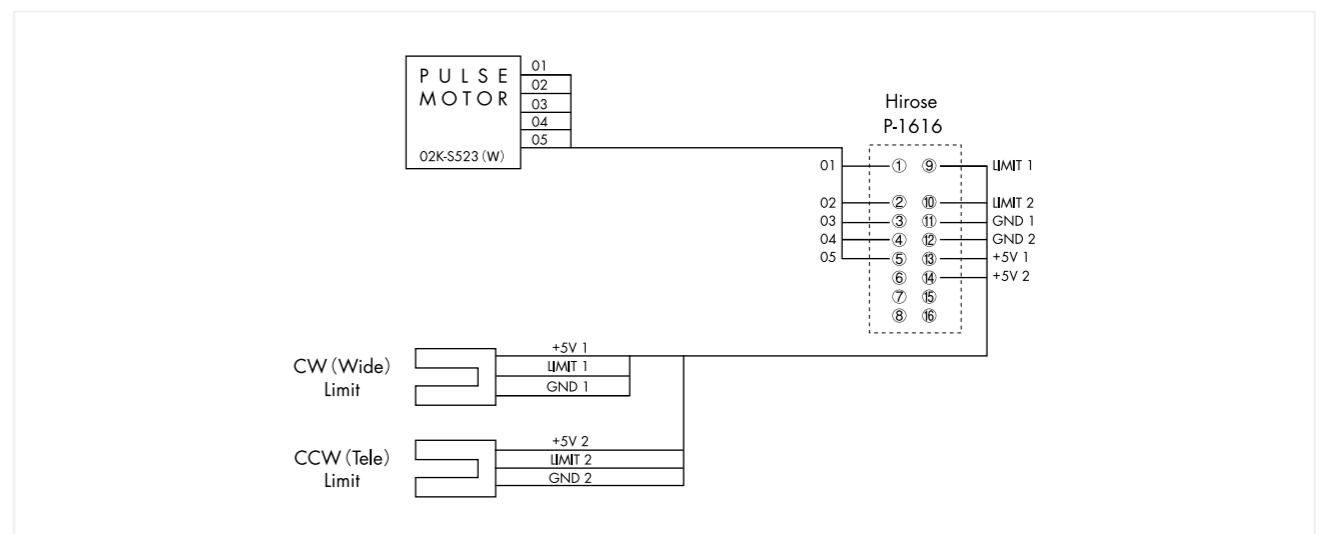

Low Magnification Zoom Lens with Co-axial Illumination

Built-in co-axial illumination
Suitable for various applications, inspection of wafer, IC chip, etc...

- 10x Zoom (0.2x - 2.0x)
- Compact design of 10x zoom ratio
- Reduce relative illumination
- High resolution at the whole magnification
- Motorized zoom type is available
- Long WD, 227mm



TLZ0220C (Manual Zoom)

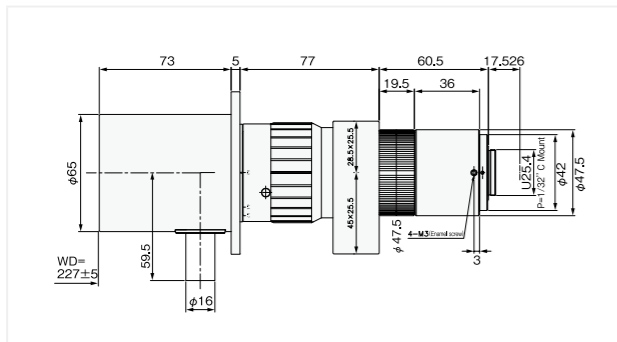

Magnification	0.2x-2.0x	Depth of field	13.1mm - 0.45mm
WD	227mm	TV distortion	-0.16% - 0.16%
Resolution	22.4μ - 7.6μ	Maximum Compatible sensor	1/1.8
Object side NA	0.015 - 0.044mm		

* Indicated specifications are design values. *Resolution indicates a theoretical resolution at a wavelength of 550nm.
*Depth of field is calculating assuming a horizontal 320 TV resolution using 1/2" camera (permissible circle of confusion 40μ).

TLZ0220C-SM (Motorized Zoom)

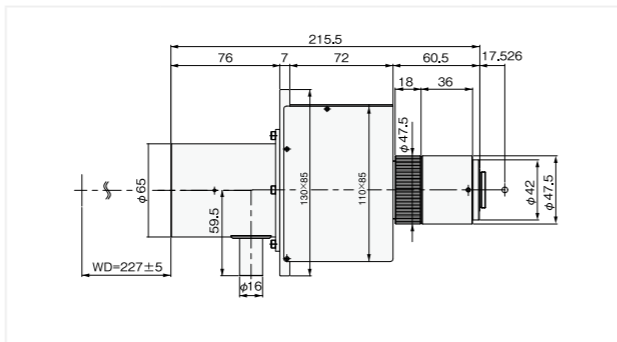

Magnification	0.2x - 2.0x	Depth of field	13.1mm - 0.45mm
WD	227mm	TV distortion	-0.16% - 0.16%
Resolution	22.4μ - 7.6μ	Maximum Compatible sensor	1/1.8
Object side NA	0.015 - 0.044mm		

(Wiring Diagram) TLZ0220C-SM

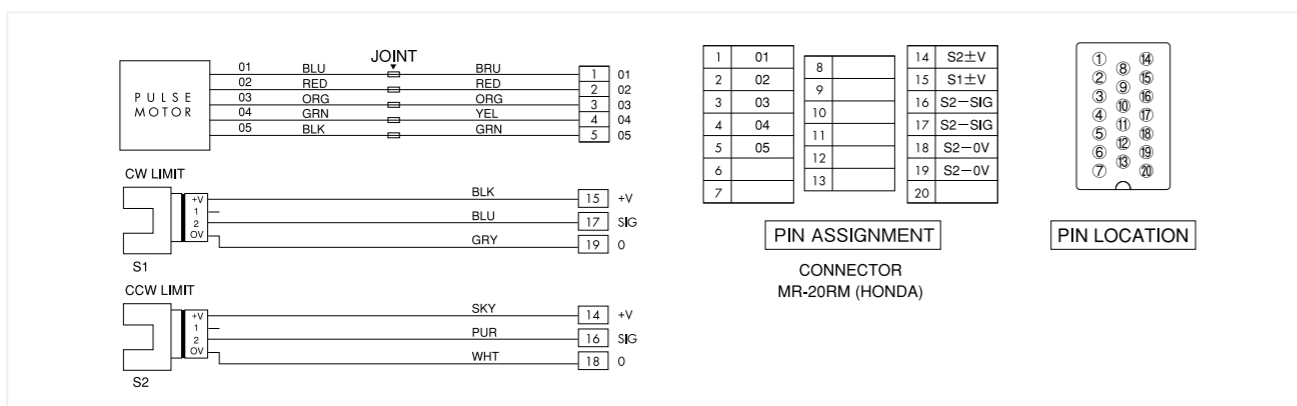

8.0x Compact Macro Zoom Lens

Compact and wide zoom ratio, suitable for inspection of various objects

- Long WD, 180mm
- Focus function is available
- φ29mm, suitable for small and limited spaces



NEW CMZ0540-2

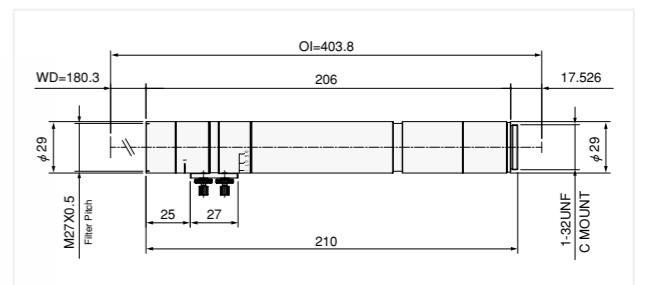

Magnification	0.5x~4.0x	Depth of field	3.3~0.19mm
WD	180.3mm	TV distortion	0.02%
Resolution	14μ~6.3μ	Maximum Compatible sensor	1/3
Object side NA	0.024~0.053		

* Indicated specifications are design values.
*Resolution indicates a theoretical resolution at a wavelength of 550nm.
*Depth of field is calculating assuming a horizontal 320 TV resolution using 1/2" camera (permissible circle of confusion 40μ).

6.0x Zoom Lens

Suitable for high speed applications

- WD500mm - ∞
- *Macro photography: Possible to use at WD10mm by pulling a macro lever
- Large aperture, suitable for high speed camera



PH6 x 8Macro

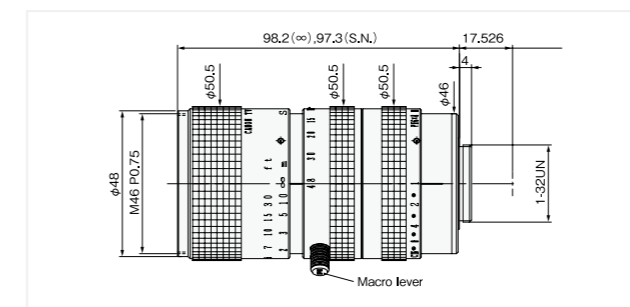

Model Focal length (Zoom Ratio)	8 - 48mm (6.0x)	Magnification at WD500mm	0.017 - 0.1
∞F No.	1.0	Filter Pitch	M46 P=75
WD	500mm - ∞	Maximum Compatible sensor	1/2

* Indicated specifications are design values.

J6 x 11Macro

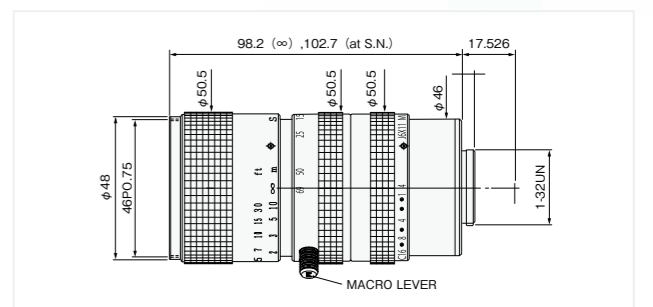

Model Focal length (Zoom Ratio)	11.5 - 69mm (6.0x)	Magnification at WD500mm	0.024 - 0.14
∞F No.	1.4	Filter Pitch	M46 P=75
WD	500mm - ∞	Maximum Compatible sensor	2/3