

SVCam-EXO

GigE-Vision, Camera Link and USB3 camera series, VGA up to 12 MegaPixel



SVCam-EXO

Building blocks
simplify design-in



All cameras in the EXO series are housed in the new, uniform 50 x 50 body. The precision-machined aluminum shell contains the latest CMOS and CCD sensors, such as the Sony CMOS IMX174, the improved Sony HyperHAD II CCD sensors, CMOSIS CV4000, the ON Semi KAlx50 and the Python series. Since all the members of the EXO series have the same physical size and interfaces this makes it the ideal choice for solutions with varying requirements.

Form follows requirements

With uniform size and standard interfaces comes simple interchangeability, allowing the system integrator to easily adapt a solution to varying conditions and requirements - with minimal design effort. SVS-VISTEK meets precisely these needs. The EXO series is a perfect match with its uniform form factor and feature set, combined with industry standard interfaces. A solution for virtually every case, allowing smooth and effortless up- or downscaling. Once designed in, the implementations can be varied endlessly. The electric circuitry within the EXO is optimized for low power dissipation resulting in cool operation. Features and functions as well as the interfaces (GigE Vision, CameraLink and USB3 Vision) are the same as in the ECO, EVO and HR series. This allows interchangeability between the series as well.

With the EXO series SVS-VISTEK is proud to announce the built-in 4io-interface. A truly powerful feature that allows up to 4 LED illumination sources to be individually driven and controlled. Imagine the savings in cost and effort working with one standard SDK brings. A true workhorse ready to meet a wide variety of needs. A robust camera at a reasonable cost level. Bringing together a wide range of the latest CCD and CMOS sensors in uniform housing concept. Easy to integrate, thanks to the use of standardized connectors and pin-outs across all series. Backed up by industry standard digital video interfaces. Physical size is not the only parameter for measuring performance.



Features with real value: Power your LED light directly from the EXO series and use it as an innovative strobe controller.

All versions of the SVCam-EXO series have the following features:

- > Progressive Scan CCD sensors
- > Global Shutter CMOS sensors
- > 0.3 to 12 Mega Pixel
- > Monochrome and color versions (Bayer Pattern)
- > Various trigger (int./ext./free running) and exposure modes
- > Logic-Trigger functions
- > Adjustable gain, auto gain and auto-exposure
- > Various binning modes
- > Partial Scan / Area of interest modes (AOI)
- > White balance for color versions
- > C-Mount or M42-Mount lens interface
- > 8/12 Bit video data stream (14 Bit ADC)
- > 64 MB memory inside
- > 4 x power output (open drain)
- > Programmable Sequencer for Sutter and LED light
- > Tap Balancing
- > SDK for Windows XP/8 (32/64 Bit) and Linux available
- > GenICam standard compliant

GigE Vision

Allows easy and quick interchangeability between hardware resulting in shorter design cycles and reduced development costs.

- > Cost effective
- > Wide range of „off the shelf“ industrial-standard plugs and cables
- > High bandwidth data transfer rate (120 MB/sec per Output)
- > Up to 100 m range without extra switch
- > Wide range of applications in image processing
- > Remote service capability

USB3 Vision

The bidirectional Universal Serial Bus warrants a high degree of compatibility regardless of the computing platform (PC, tablet, embedded ARM). The new USB3 Vision standard provides a cost effective and universal alternative for novel and flexible uses of machine vision.

- > Up to 3 Gbit/sec (625MB/sec) transfer rate.
- > Leverages existing infrastructure for cables and connectors
- > Powers camera with up to 4.5W
- > GenICam compliant
- > Cost effective / Easy implementation and interfacing

Camera Type	Sensor Size diag.	Resolution [Pixel]	Pixel Size [μm]	Architecture	Lens Mount	Dimensions [mm]	max. Frame Rate [fps]		
exo174	1/1.2"	1,920 x 1,200	5.86 x 5.86	CMOS	C	50 x 50 x 47**	46	50	162*
exo674	2/3"	1,920 x 1,460	4.54 x 4.54	CCD	C	50 x 50 x 47**	20	20	26*
exo695	1"	2,752 x 2,204	4.54 x 4.54	CCD	C	50 x 50 x 47**	13	13	25*
exo815	1"	3,360 x 2,712	3.69 x 3.69	CCD	C	50 x 50 x 47**	9	9	9*
exo834	1"	4,242 x 2,830	3.1 x 3.1	CCD	C	50 x 50 x 47**	7	7	7*
exo4000	1"	2,048 x 2,048	5.5 x 5.5	CMOS	C	50 x 50 x 47**	15	15	90*
exo1050	1/2"	1,024 x 1,024	5.5 x 5.5	CCD	C	50 x 50 x 47**	60	90	90*
exo4022	1"	2,048 x 2,048	7.4 x 7.4	CCD	M42	50 x 50 x 47**	15	25	25*
exo4070	1"	2,048 x 2,048	7.4 x 7.4	CCD	M42	50 x 50 x 47**	15	25	25*
exo4050	1"	2,336 x 1,752	5.5 x 5.5	CCD	C	50 x 50 x 47**	15	25	25*
exo300*	1/4"	640 x 480	4.8 x 4.8	CMOS	C	50 x 50 x 47**	300	300	850*
exo500*	1/3.6"	800 x 600	4.8 x 4.8	CMOS	C	50 x 50 x 47**	200	200	560*
exo1300*	1/2"	1,280 x 1,024	4.8 x 4.8	CMOS	C	50 x 50 x 47**	75	75	210*
exo2000*	2/3"	1,920 x 1,200	4.8 x 4.8	CMOS	C	50 x 50 x 47**	40	40	150*
exo5000*	1"	2,592 x 2,048	4.8 x 4.8	CMOS	C	50 x 50 x 47**	15	15	60*

* Preliminary ** +/- 3 mm, depending on interface

Camera Link

Camera Link is the most direct digital connection to the sensor and preferred by integrators with high demands on bandwidth and integration in existing systems.

- > GenICam compliant
- > ConvCam Software controle
- > Particle Image Velocimetry (PIV-Mode, for CCD sensors)

Versatile IO Concept

All EXO models are equipped with the 4io-Interface provide full control of timing and illumination via the camera SDK. Each of the 4 outputs can be individually configured and managed using pulse-width control. The integrated sequencer allows multiple exposures with varied settings to be programmed, creating new and cost effective options.

- > 4 x open drain in and out-put
- > Power MOSFET Transistors
- > PWM strobe control
- > Sequencer for various configurations
- > Programmable via Ethernet & SDK

Connector pin-out

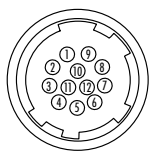

- 1 VIN- (GND)
- 2 VIN+ (10V to 25V DC)
- 3 RXD (RS232)
- 4 TXD (RS232)
- 5 IN1 (0-24V)
- 6 IN2 (0-24V)
- 7 OUT1 (open drain)
- 8 OUT2 (open drain)
- 9 IN3 (0-24V)
- 10 IN4 (0-24V)
- 11 OUT3 (open drain)
- 12 OUT4 (open drain)

Dimensions [mm]

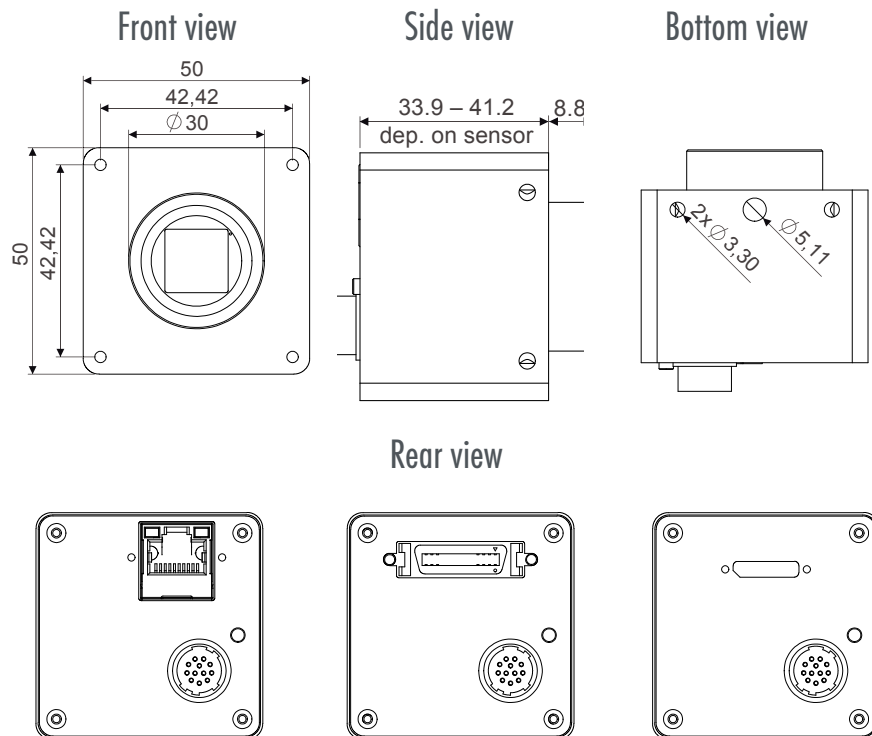

Application Areas

SVCam cameras can be found in a broad range of industries:

- > Aerospace
- > Automotive
- > Beverage
- > Food
- > Information
- > Mechanical engineering
- > Medical technology
- > Optical metrology
- > Pharmaceutical
- > Photovoltaic/power engineering
- > Plastics
- > Printing
- > Semiconductor
- > Wood and Timber
- > Traffic monitoring
- > Intelligent Transportation Systems (ITS)



SVCam – High-performance CCD cameras made in Germany

„SVCam“ is a universal family of machine vision cameras, representing the leading edge of performance, with a modular design that allows tailoring to specific customer requirements:

SVCam-ECO

Best choice for the small wallet. Impresses with its minimal footprint, without compromising on performance. VGA up to 5 megapixel. GigE Vision interface featuring PoE. Can be delivered in a housing with high IP rating (BlackLine series).

SVCam EXO

The natural choice for users requiring a high degree of flexibility. Featuring a wide range of CCD and CMOS sensors, paired with GigE Vision, CameraLink or USB3 Vision interface. Incorporates a unique LED illumination driver for individual control of up to 4 strobe lights.

SVCam-EVO

Combining high-resolution performance of CCD and CMOS sensors up to 12 Megapixels with unsurpassed speed performance of Dual GigE Vision or Camera Link interfaces. Offering a wide range of user-friendly features and functions.

SVCam-HR

The top of the line product range targeting applications for which a compromise on quality is not an option. Fulfilling even the toughest demands for resolution combined with extremely high data rate.

SVIndividual

Application specific tailoring of cameras and imaging components to your unique requirements. SVS-VISTEK has more than two decades of experience in providing customized solutions for system integrators and builders. Ranging from non-branded housings to modification of mechanical or circuit designs. Challenge us with your ideas!

Supported Interfaces

CoaxPress
The next generation digital interface

GEN<i>CAM

GigE
VISION

CAMERA
Link

USB
VISION

For more information our sales team will be pleased to assist you with expert advice. Please contact us.



SVS-VISTEK GmbH

Mühlbachstr. 20
82229 Seefeld/Germany
Tel. +49-(0) 81 52-99 85-0,
Fax +49-(0) 81 52-99 85-79
info@svs-vistek.com
www.svs-vistek.com

Scale your vision.