

PoCL

(Power over Camera Link)

Mini CL

(Mini Camera Link)

Cameras for Industries



Actual Size



Black & White

KP-F500 PCL (PoCL)
KP-F500 SCL (Mini CL)

Effective 5.05 Megapixel
16 frame / second

Actual Size



Black & White

KP-F230 PCL (PoCL)
KP-F230 SCL (Mini CL)

Effective 2.01 Megapixel
30 frame / second

Black & White

KP-F31 PCL (PoCL)
KP-F31 SCL (Mini CL)

Effective 0.33 Megapixel
120 frame / second

Actual Size



Black & White

KP-F200 PCL (PoCL)
KP-F200 SCL (Mini CL)

Effective 2.01 Megapixel
15 frame / second

Black & White

KP-F80 PCL (PoCL)
KP-F80 SCL (Mini CL)

Effective 0.81 Megapixel
36 frame / second

Black & White

KP-F39 PCL (PoCL)
KP-F39 SCL (Mini CL)

Effective 0.33 Megapixel
91 frame / second

Black & White

KP-F30 PCL (PoCL)
KP-F30 SCL (Mini CL)

Effective 0.33 Megapixel
60 frame / second

Black & White Separate type

KP-FB30 PCL (PoCL)
KP-FB30 SCL (Mini CL)

Effective 0.33 Megapixel, 60 frame / second



HITACHI



Colour

KP-FD202 PCL (PoCL)
KP-FD202 SCL (Mini CL)

Effective 2.01 Megapixel
30 frame / second

Colour

KP-FD140 PCL (PoCL)
KP-FD140 SCL (Mini CL)

Effective 1.45 Megapixel
30 frame / second

Actual Size

Mini CL (Mini Camera Link)

By adopting a Camera Link digital interface, higher speed video data transfer is possible.

Furthermore, by adopting the small connector (SDR) of a Mini Camera Link standard, the size of the camera has been reduced.

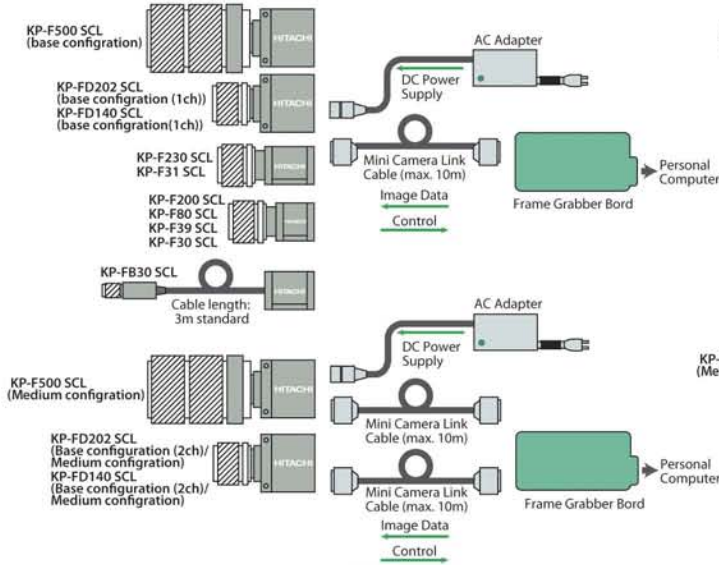

PoCL (Power over Camera Link)

The PoCL version is connected by a single (PoCL) Mini Camera Link cable directly to a frame grabber supporting PoCL. Simple systems construction is possible.

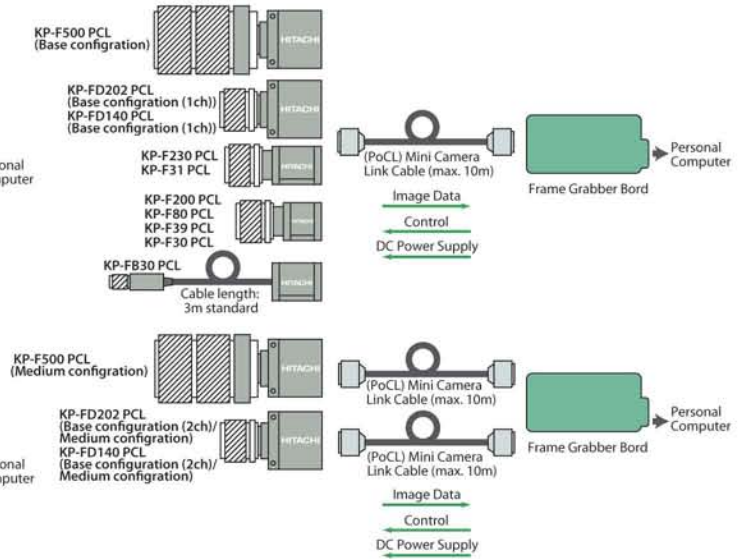

Specifications

KP-F500 PCL / SCL		KP-F230 PCL / SCL		KP-F31 PCL / SCL		KP-FB30 PCL / SCL	
Imaging device	2/3-inch interline CCD	Imaging device	1/1.8-inch interline CCD	1/3-inch interline CCD			
Total pixels	2536 (H) x 2068(V)	Total pixels	1688 (H) x 1248(V)	692 (H) x 504(V)			
Effective pixels	2456 (H) x 2058(V)	Effective pixels	1628 (H) x 1236(V)	659 (H) x 494(V)			
Active pixels	2448 (H) x 2050(V)	Active pixels	1628 (H) x 1236(V)	659 (H) x 494(V)			
Pixel size	3.45 (H) x 3.45 (V) μm (square lattice)	Pixel size	4.4 (H) x 4.4 (V) μm (square lattice)	7.4 (H) x 7.4 (V) μm (square lattice)			
Sensing area	9.93 (H) x 8.70 (V) mm	Sensing area	7.16 (H) x 5.44 (V) mm	4.88 (H) x 3.66 (V) mm			
Scanning system	Progressive	Scanning system	Progressive				
Aspect ratio	4:3	Aspect ratio	4:3				
Frame rate	16 frames/second	Frame rate	30 frames/second	120 frames/second	60 frames/second		
Horizontal drive frequency	64.000 MHz	Horizontal drive frequency	72.000 MHz	49.090902 MHz	24.5454 MHz		
Horizontal scanning frequency	33.264 kHz	Scanning frequency	Horizontal: 37.5 kHz Vertical: 30 Hz	Horizontal: 62.94 kHz Vertical: 119.88 Hz	Horizontal: 31.468 kHz Vertical: 59.94 Hz		
Vertical scanning frequency	16.00 Hz	Sync system	Internal				
Sync system	Internal	Lens mount	C mount			Special mount	
Lens mount	C mount	Flange focal distance	17.526 mm				
Flange focal distance	17.526 mm	Video output	Digital output Camera Link				
Video output	Digital output Camera Link Clk = 64 MHz x 1ch or 32 MHz x 2ch	Resolution	Horizontal/Vertical: 1200 TV lines	Clk = 24.5454 MHz x 2TAP	Clk = 24.5454 MHz		
Resolution	Horizontal/Vertical: 2000TV lines	Sensitivity	400 lx, F4, 3200 K	Horizontal: 500 TV line Vertical: 490 TV lines			
Sensitivity	400 lx, F4, 3200 K	Minimum illumination	7.4 lx, F1.4, MAX GAIN				
Minimum illumination	1.0 lx, F1.4, MAX GAIN, without IR cut filter	Signal noise to ratio	45 dB	50 dB			
Signal noise to ratio	50 dB	Electronic shutter speed	1/30 to 1/100000 second (variable setting)	1/120 to 1/100000 second (variable setting)	1/60 to 1/100000 second (variable setting)		
Electronic shutter speed	1/16, 1/60, 1/100, 1/250, 1/1000, 1/2,000, 1/10,000, 1/50,000 second. Factory setting is off (1/16 second) or changeable by variable shutter (Minimum 1/100,000 second)	Gamma compensation	$\gamma = 1$				
Gamma compensation	$\gamma = 1$	Frame on demand	One trigger, fixed shutter and VD reset				
Frame on demand	Remote setting (fixed shutter, one trigger and VD reset) Factory setting is all off.	Partial scan	Selectable start position and width of picture grabbing in 1H step.				
Partial scan	Selectable start position and width of picture grabbing in 1H step.	Offset	0 to 128 steps level/10bit 33 steps variable (Factory setting: 0 steps level)			16 to 128 steps level/10bit 29 steps variable Factory setting: 16 steps level	
Ambient temperature	Operating: 0 to +40°C (+32 to +104°F), less than 90% RH Storage: -10 to +50°C (+14 to +122°F), less than 70% RH	Gain setting	0 to +12 dB (128 steps variable)			0 to +12 dB (301 steps variable)	
Power supply voltage	12 ±1 VDC	Ambient temperature	Operating: 0 to +40°C (+32 to +104°F), less than 90% RH Storage: -10 to +50°C (+14 to +122°F), less than 70% RH				
Current consumption	Approx. 400 mA (Approx. 4.8 W)	Power supply voltage	12 ±1 VDC				
External dimensions	44 (W) x 44 (H) x 41 (D) mm	Current consumption	Approx. 270 mA (Approx. 3.3 W)	Approx. 200 mA (Approx. 2.4 W)	Approx. 205 mA (Approx. 2.4 W)		
Mass	Approx. 110 g	External dimensions	29 (W) x 29 (H) x 38 (D) mm	29 (W) x 29 (H) x 38 (D) mm	Head: 12 (W) x 12.5 (H) x 47.5 (D) mm CCU: 29 (W) x 29 (H) x 38 (D) mm		
		Mass	Approx. 60 g			Head: Approx. 18 g CCU: Approx. 50g (without cable)	

High Resolution & High Speed

High resolution combined with high frame rates are possible with this series of cameras.

Can be used for high-precision and high-speed image processing in many applications.

Then camera list

Black & White Cameras

KP-F500 PCL/SCL	5.05 Megapixel (2456(H)x2058(V))	16 frame/second
KP-F230 PCL/SCL	2.01 Megapixel (1628(H)x1236(V))	30 frame/second
KP-F200 PCL/SCL	2.01 Megapixel (1628(H)x1236(V))	15 frame/second
KP-F80 PCL/SCL	0.81 Megapixel (1034(H)x779(V))	36 frame/second
KP-F31 PCL/SCL	0.33 Megapixel (659(H)x494(V))	120 frame/second
KP-F39 PCL/SCL	0.33 Megapixel (659(H)x494(V))	91 frame/second
KP-F30 PCL/SCL	0.33 Megapixel (659(H)x494(V))	60 frame/second
KP-FB30 PCL/SCL	0.33 Megapixel (659(H)x494(V))	60 frame/second

Colour Cameras

KP-FD202 PCL/SCL	2.01 Megapixel (1628(H)x1236(V))	30 frame/second
KP-FD140 PCL/SCL	1.45 Megapixel (1392(H)x1040(V))	30 frame/second

Frame Shutter

Higher resolution in the vertical directional is ensured for moving object.

Multi-step Shutter

Provided multi-step shutter or variable shutter (minimum 1/100,000 second).

Frame on Demand

The trigger and the shutter can be used to capture an image at the desired timing and the accumulation time.

Remote Control

Through the Camera Link interface, various setting such as shutter, mode, gain, partial scan, bit width, etc can be adjusted.

Partial Scan

The start position and width of the image can be adjusted. Higher frame rates are possible by using partial scan mode.

Selectable bit width

Selectable bit width of

12-/10-/8-bit	KP-F500 PCL/SCL
10-/8-bit	KP-F230 PCL/SCL, KP-F200 PCL/SCL, KP-F80 PCL/SCL, KP-F31 PCL/SCL, KP-F39 PCL/SCL, KP-F30 PCL/SCL, KP-FB30 PCL/SCL,
36-/30-/24-bit	KP-FD202 PCL/SCL, KP-FD140 PCL/SCL

High Colour Fidelity (KP-FD202 PCL/SCL, KP-FD140 PCL/SCL)

RGB primary colour mosaic filter achieve a high colour fidelity.

Selectable White Balance Adjustment

(KP-FD202 PCL/SCL, KP-FD140 PCL/SCL)

Selectable white balance adjustment method of ATW (auto-tracking), Manual (manual setting of R and B gain) or One-push (one-push auto adjustment)

6-Vector Independent Masking

(KP-FD202 PCL/SCL, KP-FD140 PCL/SCL)

Saturation and hue of primary colours R, G, B and complementary colours Cy, Mg, Ye can be independently varied. It is effective at a application (Image capture, microscope, etc) needed highly accurate colour fidelity.



KP-F200 PCL / SCL
KP-F39 PCL / SCL

KP-F80 PCL / SCL
KP-F30 PCL / SCL

KP-FD202 PCL / SCL
KP-FD140 PCL / SCL

Specifications

	KP-F200 PCL / SCL	KP-F80 PCL / SCL	KP-F39 PCL / SCL	KP-F30 PCL / SCL
Imaging device	1/1.8-inch interline CCD	1/3-inch interline CCD		
Total pixels	1688 (H) x 1248 (V)	1077 (H) x 788 (V)	692 (H) x 504 (V)	
Effective pixels	1628 (H) x 1236 (V)	1034 (H) x 779 (V)	659 (H) x 494 (V)	
Active Pixels	1628 (H) x 1236 (V)	1024 (H) x 768 (V)	659 (H) x 494 (V)	
Pixel size	4.4 (H) x 4.4 (V) um	4.65 (H) x 4.65 (V) um	7.4 (H) x 7.4 (V) um	(square lattice)
Sensing area	7.16 (H) x 5.44 (V) mm	4.81 (H) x 3.62 (V) mm	4.88 (H) x 3.66 (V) mm	
Scanning system	Progressive			
Aspect ratio	4:3			
Frame rate	15 frames/second	36 frames/second	91 frames/second	60 frames/second
Scanning frequency	Horizontal: 18.75 kHz Vertical: 14.97 Hz	Horizontal: 28.346 kHz Vertical: 35.79 Hz	Horizontal: 46.875 kHz Vertical: 91.73 Hz	Horizontal: 31.468 kHz Vertical: 59.94 Hz
Sync system	Internal			
Lens mount	C mount (Flange focal distance=17.526 mm)			
Video output	Digital output Camera Link Clk = 36 MHz		Digital output Camera Link Clk = 24.5454 MHz	
Resolution	Horizontal/Vertical: 1200 TV lines	Horizontal/Vertical: 800 TV lines	Horizontal: 500 TV line Vertical: 490 TV lines	
Sensitivity	400 lx, F4, 3200 K	400 lx, F2.8, 3200 K	400 lx, F4, 3200 K	
Minimum illumination	1.0 lx, F1.4, MAX GAIN, without IR cut filter	7.4 lx, F1.4, MAX GAIN, without IR cut filter	1.0 lx, F1.4, MAX GAIN, without IR cut filter	
Signal noise to ratio	50 dB			
Electronic shutter speed	1/15, 1/60, 1/125, 1/250, 1/1000, 1/2000, 1/10000, 1/50000 second. Factory setting is off (1/15 second) or changeable by variable shutter (Minimum 1/100000 second)	1/36, 1/60, 1/125, 1/250, 1/1000, 1/2000, 1/10000, 1/50000 second. Factory setting is off (1/36 second) or changeable by variable shutter (Minimum 1/100000 second)	1/91, 1/250, 1/500, 1/1000, 1/2000, 1/4000, 1/10000, 1/50000 second. Factory setting is off (1/60 second) or changeable by variable shutter (Minimum 1/100000 second)	1/60, 1/250, 1/500, 1/1000, 1/2000, 1/4000, 1/10000, 1/50000 second. Factory setting is off (1/60 second) or changeable by variable shutter (Minimum 1/100000 second)
Gamma compensation	$\gamma = 1$			
Frame on demand	Fixed shutter, one trigger and VD reset (Factory setting is all off)			
Partial scan	Selectable start position and width of picture grabbing in 1H step.			
Ambient temperature	Operating: 0 to +40°C (+32 to +104°F), less than 90 % RH Storage: -10 to +50°C (+14 to +122°F), less than 70 % RH			
Power supply voltage	12 ± 1 VDC			
Current consumption	Approx. 170 mA (Approx. 2.1 W)	Approx. 120 mA (Approx. 1.5 W)	Approx. 160 mA (Approx. 2.0 W)	Approx. 120 mA (Approx. 1.5 W)
External dimensions	29 (W) x 29 (H) x 29 (D) mm			
Mass	Approx. 50 g			

	KP-FD202 PCL / SCL	KP-FD140 PCL / SCL
Imaging device	1/1.8-inch interline CCD	1/2-inch interline CCD
Total pixels	1688(H) x 1248(V)	1434(H) x 1050(V)
Effective pixels	1628(H) x 1236(V)	1392(H) x 1040(V)
Active pixels	1600(H) x 1200(V)	1360(H) x 1024(V)
Unit cell size	4.4(H) x 4.4(V) um (square lattice)	4.65(H) x 4.65(V) um (square lattice)
Color filter	RGB primary colour mosaic filter	
Scanning system	Progressive	
Sync system	Internal	
Video output		
Interface	Camera Link standard (SDR connector)	
Output format	(a) 24 bits (R: 8 bits G: 8 bits B: 8 bits) (Base configuration) (b) 30 bits (R: 10 bits G: 10 bits B: 10 bits) (Medium configuration) (c) 36 bits (R: 12 bits G: 12 bits B: 12 bits) (Medium configuration)	
Frame rate	30 frames/second (full pixel readout)	
Scanning frequency	Horizontal: 37.5 kHz Vertical: 29.95 Hz	Horizontal: 33.519 kHz Vertical: 30.13 Hz
Camera remote	Camera Link control	
Sensitivity	2000 lx, F8, 3200 K	
Minimum illumination	5.0 lx, F1.4, MAX GAIN	
Gain	Auto/Manual (0 to +18.5dB)(Approx. 0.04dB step)	
Electronic shutter speed	1/30, 1/60, 1/100, 1/250, 1/1000, 1/2000, 1/10000, 1/50000 second. Factory setting is off (1/60 second) or changeable by variable shutter (Minimum 1/100000 second)	
Frame on demand	Fixed shutter, one trigger and VD reset Factory setting is all off	
Partial scan	Selectable start position and width of picture grabbing	
Auto Exposure (ALC: Auto level control)	Adjustable for video level	
White balance	ATW / MANUAL / One-push	
Enhanced functions	Gamma: OFF / LUT, Colour masking: OFF / ON (6 vector independent masking), Colour saturation: Adjustable, Colour level: Adjustable (Paint-black), Sharpness: Adjustable, Brightness: Adjustable	
Lens mount	C mount	
Power supply voltage	12 ± 1 VDC	
Current consumption	Approx. 400 mA (Approx. 4.8 W)	
Ambient temperature	Operating: 0 to +40°C (+32 to +104°F), less than 90 % RH Storage: -10 to +50°C (+14 to +122°F), less than 70 % RH	
External dimensions	44 (W) x 44 (H) x 41 (D) mm	
Mass	Approx. 110 g	

Rear View



KP-F500 PCL/SCL
KP-FD202 PCL/SCL
KP-FD140 PCL/SCL



KP-F230 PCL
KP-F200 PCL
KP-F80 PCL
KP-F31 PCL
KP-F39 PCL
KP-F30 PCL
KP-FB30 PCL (CCU)



KP-F230 SCL
KP-F200 SCL
KP-F80 SCL
KP-F31 SCL
KP-F39 SCL
KP-F30 SCL
KP-FB30 SCL (CCU)

Option

Tripod Adaptor



TA-F500 KP-F500 PCL/SCL, KP-FD202 PCL/SCL, KP-FD140 PCL/SCL
TA-F230 KP-F230 PCL/SCL, KP-F31 PCL/SCL, KP-FB30 PCL/SCL (CCU)
TA-F200S KP-F200 PCL/SCL, KP-F80 PCL/SCL, KP-F39 PCL/SCL, KP-F30 PCL/SCL
TA-FB30 KP-FB30 PCL/SCL (Camera Head)
TA-FB30P KP-FB30 PCL/SCL (Camera Head)

Dummy Glass

Mini Camera Link Cable (for SCL type)

Mini Camera Link Cable (PoCL support) (for PCL type)

Dimensions

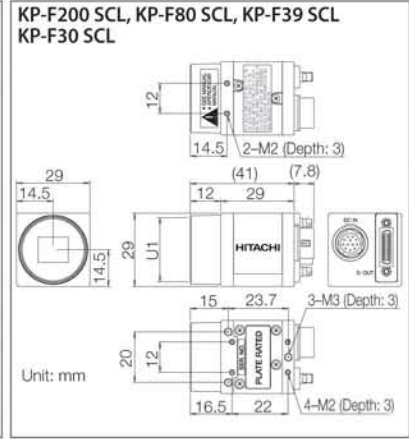
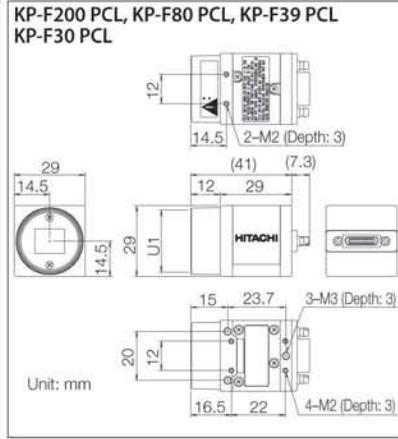
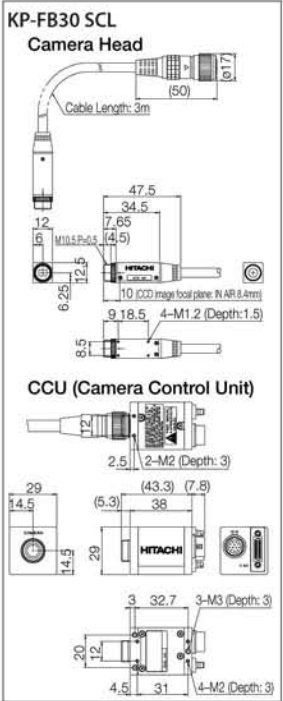
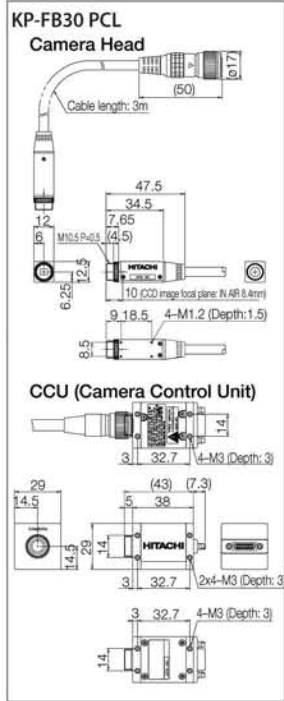
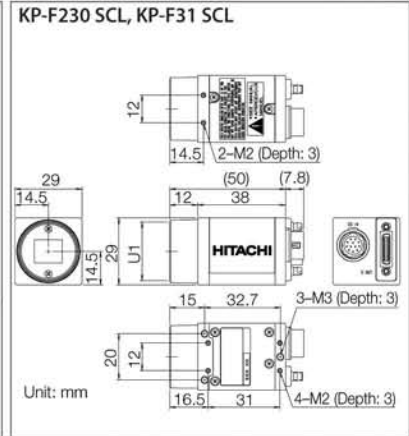
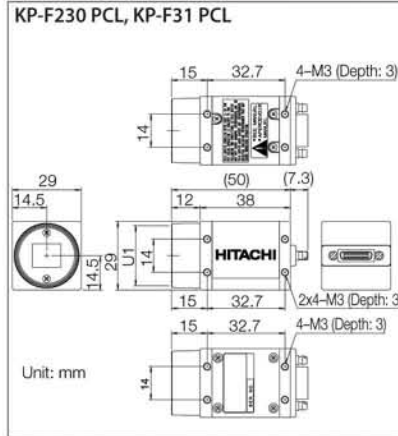
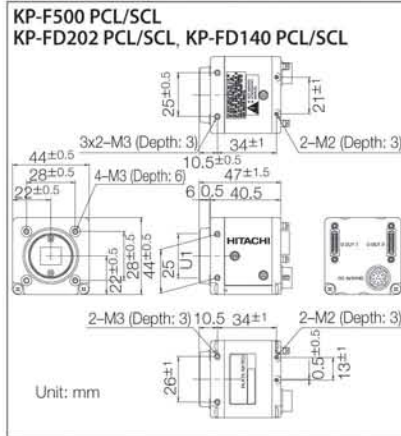

CAUTION: To ensure safe operation, please read the instruction manual before using this product.

These Specifications are subject to change without notice.

Hitachi Kokusai Electric Inc.

Head Office : 14-1, Sotokanda 4-choume, Chiyoda-ku, Tokyo 101-8980, Japan
Phone : +81(0) 3-6734-9432, Fax : +81(0) 3-5209-5942
URL : <http://www.h-kokusai.com>

Hitachi Kokusai Electric (Shanghai) Co., Ltd. Beijing Branch
Room 1413, Beijing Fortune Building, 5 Dong San Huan Bei-Lu, Chao Yang District, Beijing
Phone : +86(0) 10-6590-8755/8756, Fax : +86(0) 10-6590-8757

Hitachi Kokusai Electric America, Ltd. URL : <http://hitachikokusai.us>

Headquarters and Northeast Office : 150 Crossways Park Drive, Woodbury, New York 11797, U. S. A.
Phone : (+1) 516-921-7200, Fax : (+1) 516-496-3718

West Office : 371 Van Ness Way, Suite 120 Torrance, CA. 90501, U. S. A.
Phone : (+1) 310-328-6116, Fax : (+1) 310-328-6252

Midwest Sales : Phone : (+1) 330-334-4115, Fax : (+1) 516-496-3718

South Sales : Service (+1) 989-345-5379

Parts Center : Phone : (+1) 516-682-4435, Fax : (+1) 516-921-0993

Latin Sales : Phone : (+1) 516-682-4420, Fax : (+1) 516-496-3718

Hitachi Kokusai Electric Canada, Ltd. URL : www.hitachikokusai.ca

Head Office : 1 Select Avenue Unit #11 Scarborough, Ontario M1V 5J3, Canada
Phone : (+1) 416-299-5900, Fax : (+1) 416-299-0450

Eastern Office : 5795 Chemin St. Francois St. Laurent, Quebec H4S 1B6, Canada
Phone : (+1) 514-332-6687, Fax : (+1) 514-335-1664

Hitachi Kokusai Electric Europe GmbH

Head Office : Weiskircher Straße 88, Jügesheim D-63110 Rodgau, Germany
Phone : +49(0) 6106-69920, Fax : +49(0) 6106-16996

Hitachi Kokusai Electric U.K. Ltd.

Head Office : Windsor House, Britannia Road, Waltham Cross, Hertfordshire EN8 7NX, United Kingdom
Phone : +44(0) 845-121-2177, Fax : +44(0) 845-121-2180
URL : www.hitachi-ke-eu.com
General email address : uksales@hitachi-ke-eu.com



CERTIFICATE No.
JMI-0062
ISO 9001/BS 5750Pt1
EN 29001/JIS 29901

Progressive scan CMOS camera

KP-FM200WCL (Mono)/ KP-FMR200WCL (Color)

Preliminary



What's WCL Camera Link

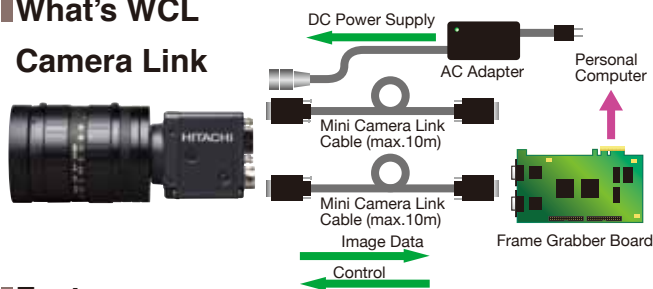

Automatic power supply change. PoCL

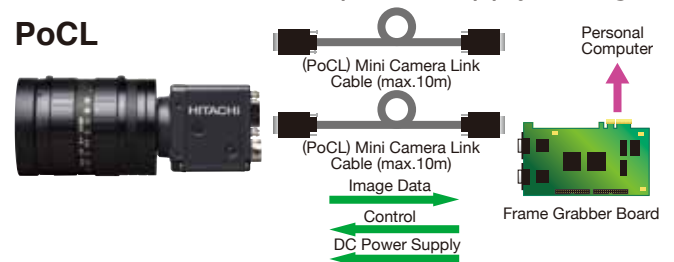

Features

- The 2/3-inch 2M pixels square lattice progressive scan CMOS achieve a high resolution of 2048(H)×1088(V).
- The camera has small SDR connector for digital outputs.
Therefore, the camera has the realization of small-sized shape of 44 (W)×44 (H)×41(D) mm.
- The image of 2048 (H)×1088 (V) is output at 280 frames per second.

Main specifications and functions

	KP-FM200WCL	KP-FMR200WCL
Imaging device	2/3-inch global shutter CMOS	
Effective pixels	2048 (H) × 1088 (V)	
Pixel size	5.5μm (H) × 5.5μm (V) (square lattice)	
Color filter	—	RGB primary color mosaic filter
Sensing area	11.264mm (H) × 5.984mm (V)	
Frame rate	Max 280 frames/second (full pixel readout)	
Pixel frequency	40.0000MHz	
Video output	Digital output PoCL / non-PoCL (10bits or 8bits)	
Electronic shutter (Global Shutter)	OFF, 1/70, 1/100, 1/250, 1/500, 1/1000, 1/2000, 1/10000, 1/50000 second. OFF is normal exposure (frame rate) or changeable by variable shutter	
Partial scan	Selectable start position and width of picture grabbing in 1H step.	
Lens mount	C mount	
Power-supply voltage/current consumption	DC12V±1VDC/Approx.200mA (Approx.2.4W)	
Ambient Performance	0 to +40°C	
External dimensions	44 (W) × 44 (H) × 41 (D) mm (Not including protrusions)	
Mass	Approx. 130g	

CAUTION : To ensure safe operation, please read the instruction manual before using this product.

These Specifications are subject to change without notice.

Hitachi Kokusai Electric Inc. URL : <http://www.hitachi-kokusai.co.jp/>

Head Office : 14-1, Sotokanda 4-choume, Chiyoda-ku, Tokyo 101-8980, Japan
Phone : +81(0)3-6734-9432, Fax : +81(0)3-5209-5942

Hitachi Kokusai Electric America, Ltd. URL : <http://hitachikokusai.us>

Headquarters and : 150 Crossways Park Drive, Woodbury, New York 11797, U.S.A.

Northeast Office : Phone : (+1)516-921-7200, Fax : (+1)516-496-3718

West Office : 11258 Monarch, Unite Garden Grove, CA 92841

Phone : (+1)310-328-6116, Fax : (+1)310-328-6252

Service : (+1)256-774-3777

Midwest Sales : Phone : (+1)330-334-4115, Fax : (+1)516-496-3718

Service : (+1)989-345-5379

South Sales : Phone : (+1)850-934-1234

Service : (+1)256-774-3777

Parts Center : Phone : (+1)516-682-4435, Fax : (+1)516-921-0993

Latin Sales : Phone : (+1)516-682-4420, Fax : (+1)516-496-3718

Hitachi Kokusai Electric Europe GmbH URL : <http://www.hitachi-keu.com>

Sales and Engineering : Siemensstr. 9, D-63263 Neu-Isenburg, Germany

Phone : +49(0) 6102-8332-0, Fax : +49(0) 6102-202616

Frankfurt office : Windsor House, Britannia Road, Waltham Cross,

Hertfordshire EN8 7NX, United Kingdom

Phone : +44(0) 845-121-2177, Fax : +44(0) 845-121-2180

London office : General email address : uksales@hitachi-keu.com

Hitachi Kokusai Electric Canada, Ltd. URL : <http://hitachikokusai.ca>

Head Office : 1 Select Avenue Unit#11 Scarborough, Ontario M1V5J3, Canada

Phone : (+1)416-299-5900, Fax : (+1)416-299-0450

Eastern Office : 5795 Chemin St. Francois St. Laurent, Quebec H4S 1B6, Canada

Phone : (+1)514-332-6687, Fax : (+1)514-335-1664



CERTIFICATE No.
JMI-0062
ISO 9001/BS 5750Pt1
EN 29001/JIS Z9901

Progressive scan CMOS camera KP-FM400WCL(Mono)



What's WCL

Camera Link

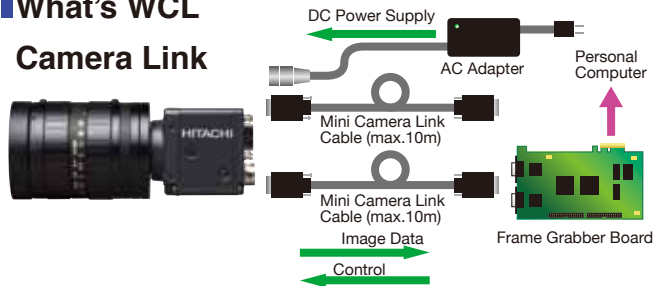

Automatic power supply change.

PoCL

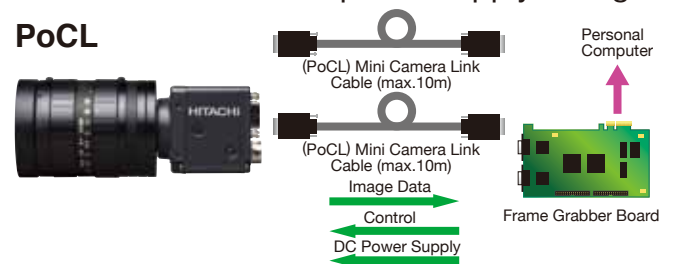

Features

- The 1-inch 4M pixels square lattice progressive scan CMOS achieve a high resolution of 2048(H) × 2048(V).
- The camera has small SDR connector for digital outputs.
Therefore, the camera has the realization of small-sized shape of 44(W) × 44(H) × 41(D) mm.
- The image of 2048(H) × 2048(V) is output at 140 frames per second.

Main specifications and functions

	KP-FM400WCL
Imaging device	1-inch progressive scan CMOS sensor
Effective pixels	2048 (H) × 2048 (V)
Vertical scanning frequency	140Hz (Full Configuration : with two cables) 70Hz (Medium Configuration : with two cables) 35Hz (Base Configuration : with one cable)
Frame rate	140 frames/second (full pixel readout)
Pixel frequency	40.0000MHz
Video output	Digital output PoCL / non-PoCL (10bits or 8bits)
Electronic shutter	1/60 to 1/50000 second or Variable shutter
Partial scan	Selectable start position and width of picture grabbing in 1H step.
Lens mount	C mount
Power-supply voltage/current consumption	DC12V±1VDC / Approx.2.3W
Ambient Performance	0 to +40°C
External dimensions	44 (W) × 44 (H) × 41 (D) mm (Not including protrusions)
Mass	Approx. 130g

CAUTION : To ensure safe operation, please read the instruction manual before using this product.

These Specifications are subject to change without notice.

Hitachi Kokusai Electric Inc. URL : <http://www.hitachi-kokusai.co.jp/>

Head Office : 14-1, Sotokanda 4-choume, Chiyoda-ku, Tokyo 101-8980, Japan
Phone : +81(0)3-6734-9432, Fax : +81(0)3-5209-5942

Hitachi Kokusai Electric America, Ltd. URL : <http://hitachikokusai.us>

Headquarters and Northeast Office : 150 Crossways Park Drive, Woodbury, New York 11797, U.S.A.
Phone : (+1)516-921-7200, Fax : (+1)516-496-3718

West Office : 11258 Monarch, Unite Garden Grove, CA 92841
Phone : (+1)310-328-6116, Fax : (+1)310-328-6252

Midwest Sales : Phone : (+1)330-334-4115, Fax : (+1)516-496-3718
Service : (+1)989-345-5379

South Sales : Phone : (+1)850-934-1234
Service : (+1)256-774-3777

Parts Center : Phone : (+1)516-682-4435, Fax : (+1)516-921-0993

Latin Sales : Phone : (+1)516-682-4420, Fax : (+1)516-496-3718

Hitachi Kokusai Electric Europe GmbH URL : <http://www.hitachi-keu.com>

Sales and Engineering : Siemensstr. 9, D-63263 Neu-Isenburg, Germany
+49(0) 6102-8332-0, Fax : +49(0) 6102-202616

Frankfurt office : Windsor House, Britannia Road, Waltham Cross,
Hertfordshire EN8 7NX, United Kingdom

London office : Phone : +44(0) 845-121-2177, Fax : +44(0) 845-121-2180

General email address : uksales@hitachi-keu.com

Hitachi Kokusai Electric Canada, Ltd. URL : <http://hitachikokusai.ca>

Head Office : 1 Select Avenue Unit#11 Scarborough, Ontario M1V5J3, Canada
Phone : (+1)416-299-5900, Fax : (+1)416-299-0450

Eastern Office : 5795 Chemin St. Francois St. Laurent, Quebec H4S 1B6, Canada
Phone : (+1)514-332-6687, Fax : (+1)514-335-1664



CERTIFICATE No.
JMI-0062
ISO 9001/BS 5750Pt1
EN 29001/JIS Z9901