

# Chameleon IP66 and IP67 (Nema 4) Industrial camera enclosure



IP66 - IP67 (Nema 4) protection for cameras with 90° viewing direction

## Technical Highlights:

- **Robust build** from aluminium or high grade stainless steel (AISI 316L).
- **Small form factor** - enclosures are not much larger than the protected camera.
- **Different sizes available** - for S-mount vision sensors and C- mount cameras with larger lenses.
- **Custom colours and prints possible.**
- **Adaptation to specific camera models:** regularly without additional costs.
- **Good chemical resistance:** through NBR, TPE and Poron seals. Contact us for any special requirements!
- **Also suitable for vision sensors with inbuilt LED lighting:** thanks to double sided anti-reflective window coating.
- **Pressure equalising valve:** avoids condensation for outdoor use.
- **Cable gland for several cables and connectors up to 26mm diameter.**

## Chameleon S, aluminium

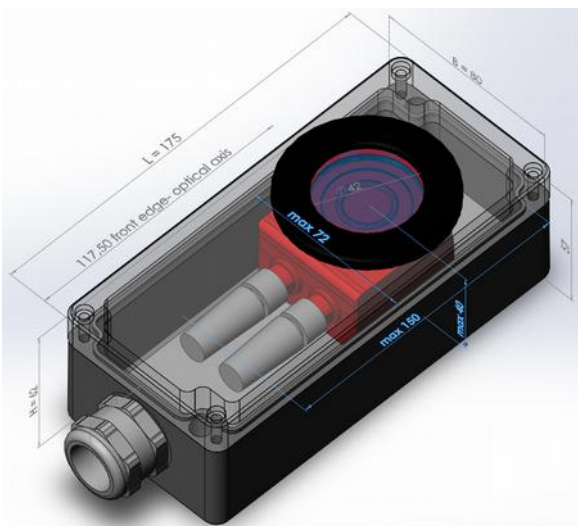

- **For vision sensors up to 150 x 72 x 44mm** (l x w x h incl. connectors).
- **Example:** Balluff BVS vision sensor.

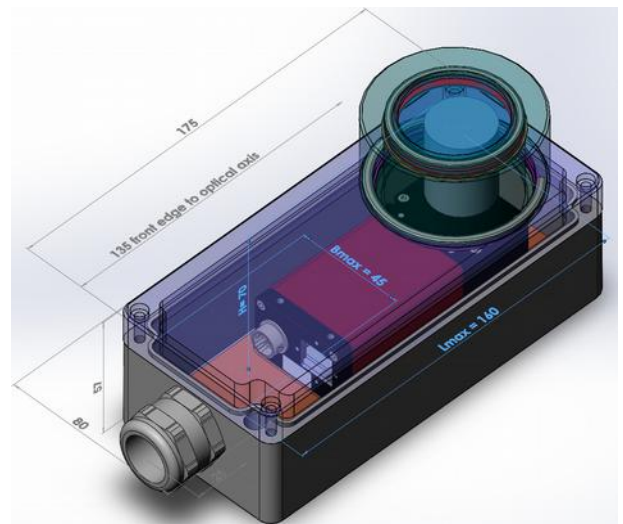

- **For angular C-Mount cameras up to 160 x 45 x 72mm** (l x w x h incl. connectors).
- **Example:** AVT Manta W90 with 35mm C-Mount lens.

Enclosure Type	Dimensions (l x w x h)	Order Number
Chameleon SW	175 x 80 x 62mm	20.100.062

Enclosure Type	Dimensions (l x w x h)	Order Number
Chameleon ST	175 x 80 x 92mm	20.100.092

# Chameleon IP66 and IP67 (Nema 4) Industrial camera enclosure

Chameleon M, stainless steel



- High grade surgical stainless steel (V4A, AISI 316L).
- Hygienic design – no concave surfaces, FDA approved seals between all metal surfaces. Special hygienic cable gland available.

Chameleon L, aluminium



- Large 3" window with 65mm aperture.
- Camera lens always close to the window: thanks to different enclosure heights of 65, 75, 80 and 90mm.
- Longer lenses can be used: combined with the Orca 60mm extension.

Enclosure Type	Dimensions (l x w x h)	Order Number
Chameleon M	198 x 89 x 71.5mm	20.102.047

Enclosure Type	Dimensions (l x w x h)	Order Number
Chameleon L65	220 x 120 x 65mm	20.105.065
Chameleon L75	220 x 120 x 75mm	20.105.075
Chameleon L80	220 x 120 x 80mm	20.105.080
Chameleon L90	220 x 120 x 90mm	20.105.090

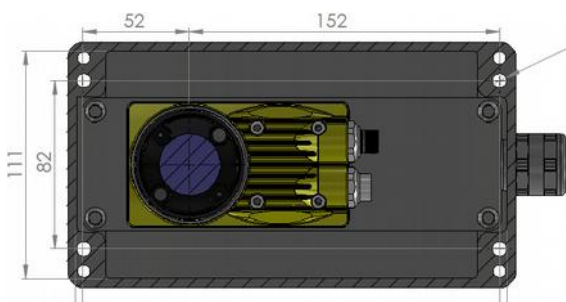
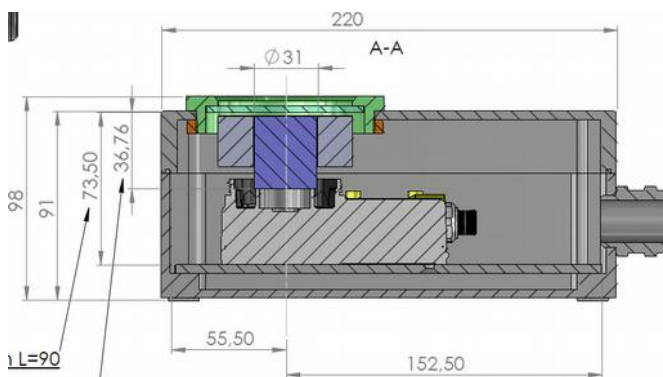

© autoVimation 2015 subject to change without notice. No liability is accepted for possible errors.