

High Magnification Machine Micro Lens

Super Optical Device-SOD-10X

The SOD-10X is the first telecentric machine vision lens that we introduced with the resolution to rival microscope objectives. The long WD and high NA have made it indispensable for high magnification alignment & inspection applications of 10x or greater.

High performance rear converters allow for magnifications of 15x & 20x to be achieved without changing the working distance allowing microscope type performance in a relatively compact package.

- 10x optical magnification
- Capable of 15x and 20x with rear converter lenses
- High NA of 0.23
- High resolution, 1.5 μ m
- Compact, integrated design

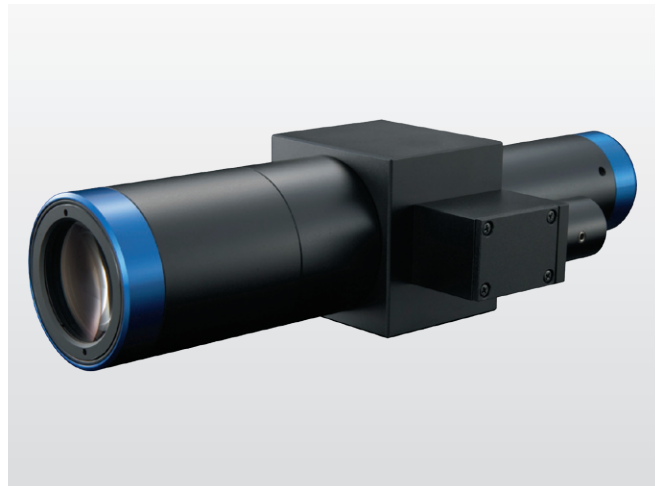

1 Even Better Images

High Resolution and NA

Achievement of high resolution that is beyond comparison with conventional machine vision lenses.

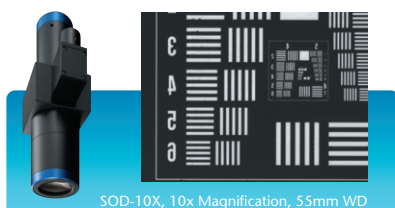
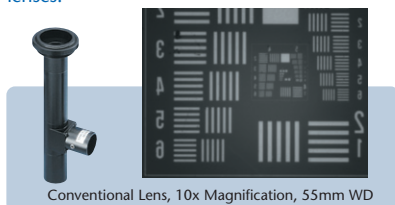

2 Wide Focus Range

Deep Depth of Field Telecentric Optical System

A high resolution equivalent to an objective lens with even longer depth of field has been sought after and now there is a telecentric optical system that has been implemented to widen the range of focus when viewing objects with a camera.

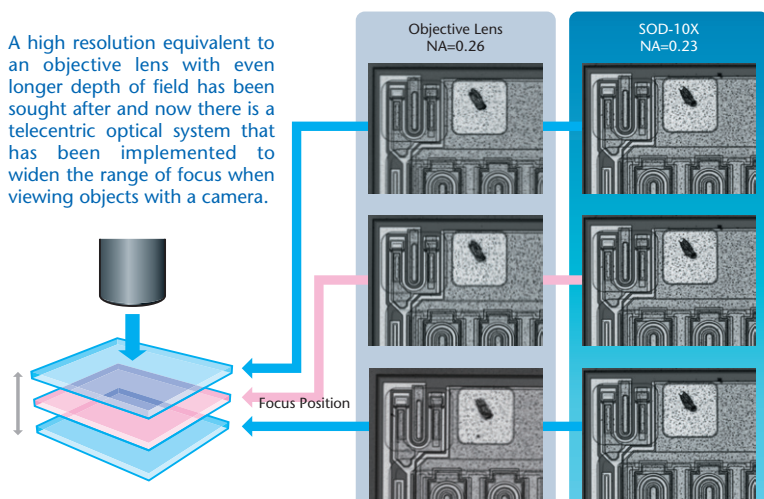

High Magnification Machine Micro Lens

Super Optical Device-SOD-20X-VI

This revolutionary 20× magnification SOD series model has a high NA & resolution that put it in the microscope objective lens class.

In addition, it boasts a long WD of 37.5 mm that provides you with additional space to install Illumination and motion, handling, & transfer systems.

The all-in-one machine vision lens has a compact body with an integrated coaxial epi-illumination also saving space & improving on-axis light quality.

- 20× optical magnification
- Capable of 30× and 40× with rear converter lenses
- High NA of 0.35
- High resolution, 1μm
- Variable iris



3 Ease of Use **Long WD**

Improved ease of use through longer WD (working distance) while maintaining high resolution.

Sufficient space for tooling and pick-up tools has been provided allowing the performance of operations thought to be impossible with conventional lenses. Operating position and work status can be confirmed by eye resulting in a reduction of operating errors.

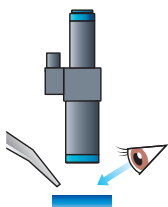

Establishment of operating space
Confirmation of operation status and position possible by eye

Opens the possibility of using not only coaxial but ring and various other types of illumination. This increase in lighting options allows for the imaging of objects previously difficult to view and resolve.

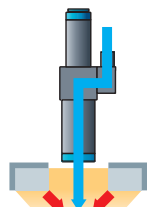

Oblique illumination is possible

Recognition is possible at a location with necessary separation from heat sources. Alignment and inspection are also possible during thermo compression bonding.

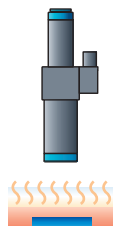

Separation from heat source

Observation can be performed without any effects from water, oil, and foreign objects generated or moved during processing.

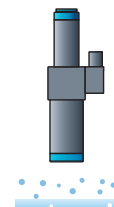

Use in environments where substances such as water & oil are disturbed

4 Compact

Compact design makes it possible to downsize peripheral parts and machinery.

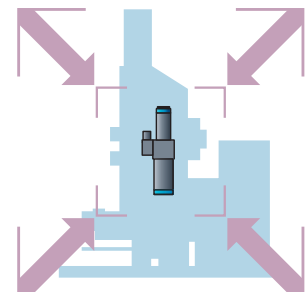

SOD-10X

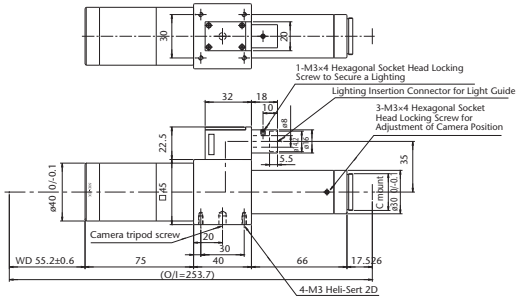

SOD-20X-VI

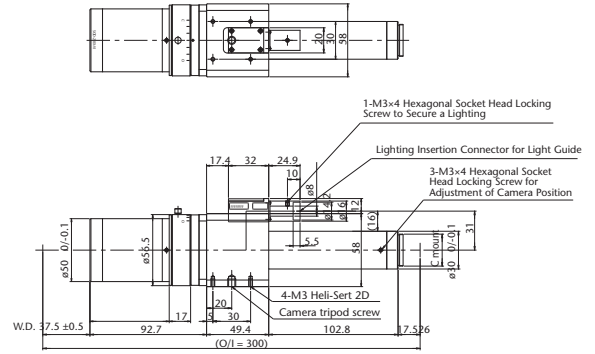

Rear Converter Lens (Option)

SOD-1.5X

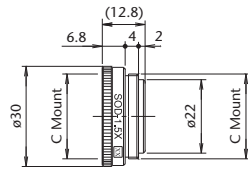

SOD-2X

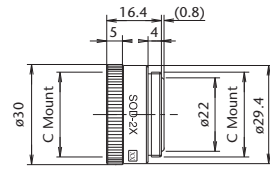

Model	Magnification	O/I	WD	Resolution	Depth of Field	NA	Effective F No	TV Distortion	Largest Compatible	Weight
SOD-10X	×10	253.7mm	55.2mm	1.5μm	0.017mm	0.23	22	0.01% or less	2/3"	500g
SOD-1.5X	×15	260.5mm	55.2mm	1.5μm	0.012mm	0.23	33	0.05% or less	2/3"	20g
SOD-2X	×20	266.1mm	55.2mm	1.5μm	0.009mm	0.23	44	0.04% or less	2/3"	30g
SOD-20X	×20	300mm	37.5mm	1μm ~ 3μm	0.0057mm ~ 0.026mm	0.35 ~ 0.113	28.3 ~ 88	0.02% or less	2/3"	930g
SOD-1.5X	×30	306.8mm	37.5mm	1μm ~ 3μm	0.0038mm ~ 0.012mm	0.35 ~ 0.113	42.5 ~ 132	0.04% or less	2/3"	20g
SOD-2X	×40	312.4mm	37.5mm	1μm ~ 3μm	0.0029mm ~ 0.009mm	0.35 ~ 0.113	56.6 ~ 176	-0.07% or less	2/3"	30g

Application Sample

Silicon Wafers

Recognition of wafer patterns using coaxial illumination. Recognition of damage and foreign objects using ring illumination.

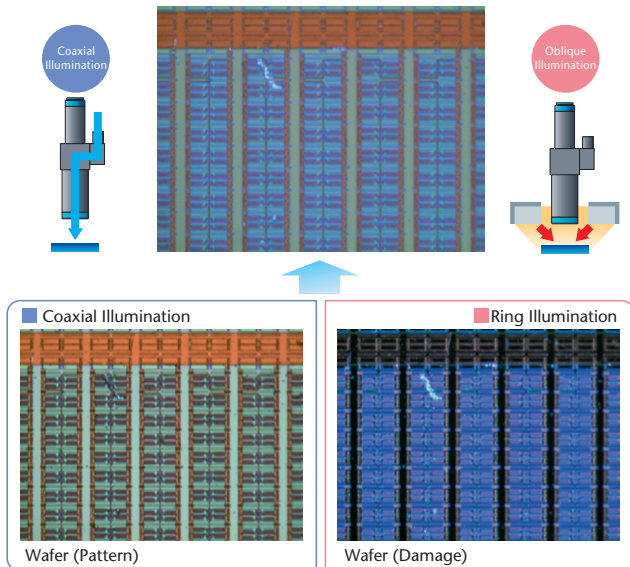

Hard Disk Reading Head

Highly uneven objects are covered by using a wide focus range.

